

MASTERS DECORATIVE SERIES®

CRYSTAL GEYSER



HORSEPOWER	½	
HT x DIA ft UPPER	8 x 20	60Hz
ELECTRICAL RATING Ph VOLTAGE AMPS	1 120 5.6 1 208-240 2.8	
HT x DIA m UPPER	1.8 x 5	50Hz
ELECTRICAL RATING Ph VOLTAGE AMPS	1 220-230 3	

BASIC FLOW PATTERN (BFP) VERTICAL

MASTERS DECORATIVE SERIES® DESIGN

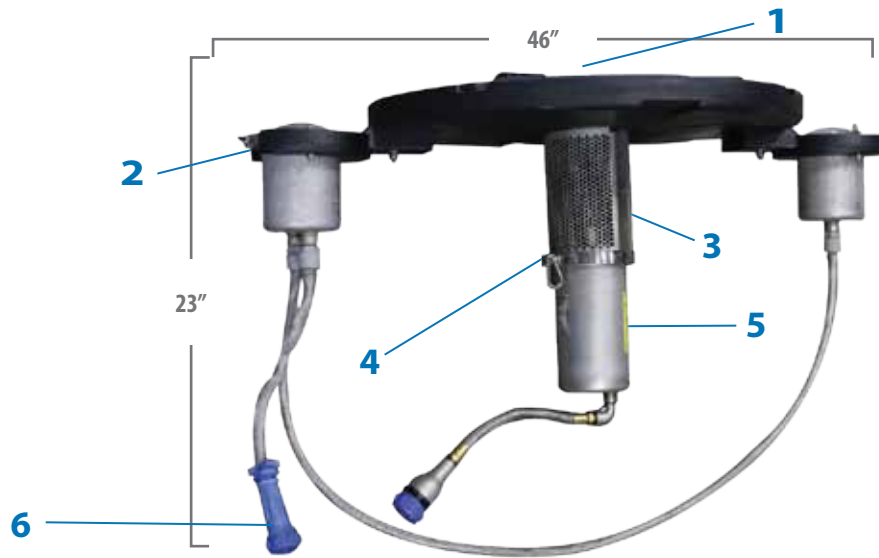

½ HP Masters Decorative Series®
 (Min. Operating Depth - 2ft.)

- 1 -** Interchangeable nozzles
- 2 -** Low profile float design with attachable light brackets for LED & RGBW Lighting
- 3 -** Stainless steel intake screen
- 4 -** Patented, high-efficiency impeller system
- 5 -** Exclusive custom-designed oil-cooled energy efficient motors with stainless steel motor housing and top plate
- 6 -** AquaLock Connector (ALC) electrical quick disconnect

MASTER THE **POWER** AND **BEAUTY** OF WATER

INSTALLATION

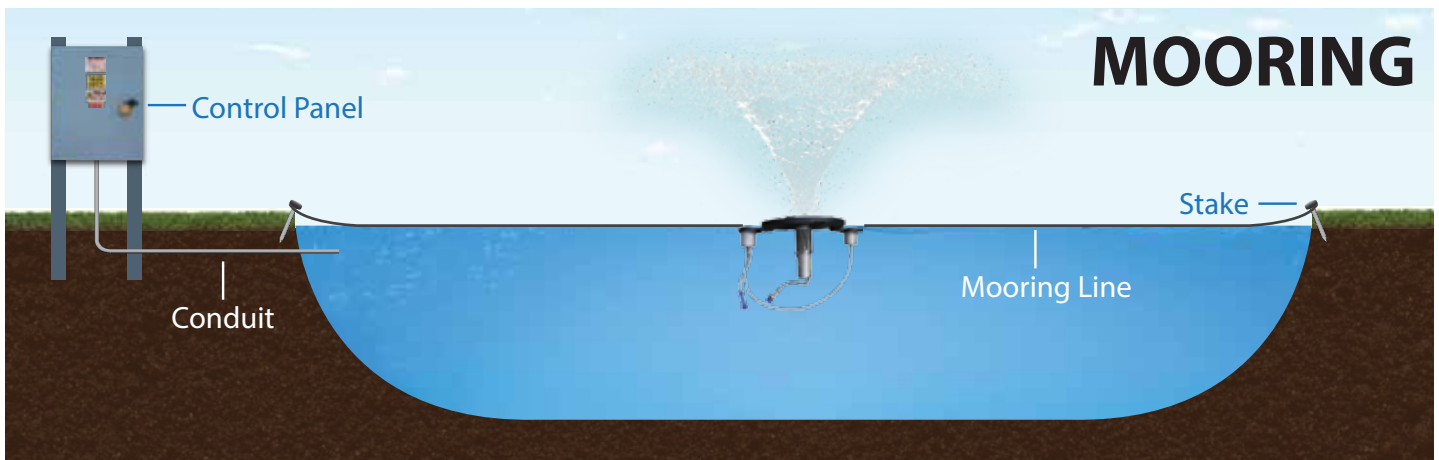
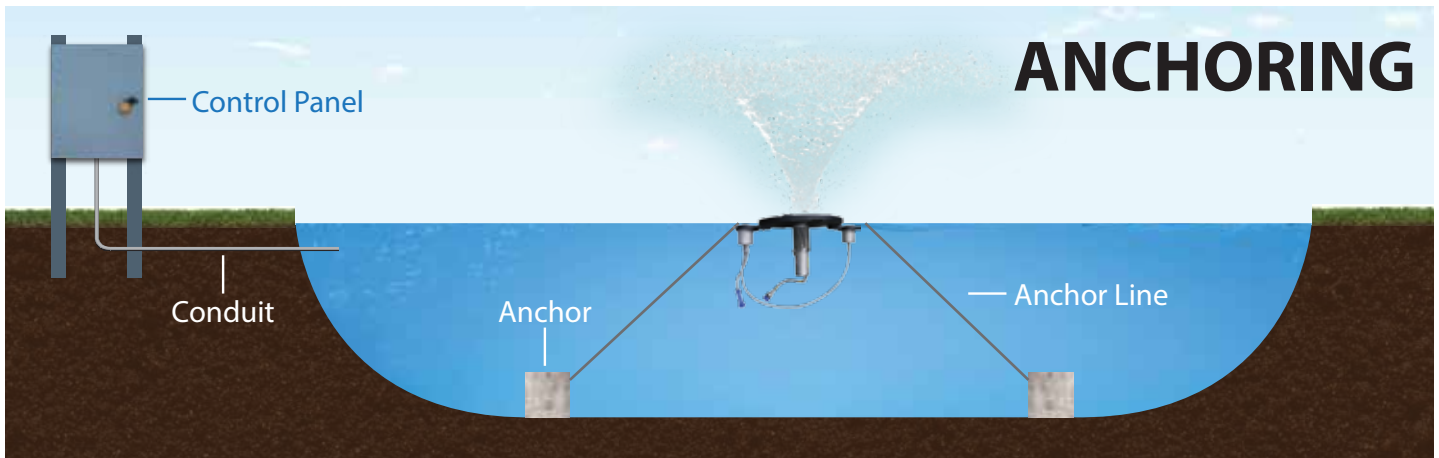

CONTROL PANEL

CONTROL PANEL OPTIONS

Standard Panel:

- Standard Panel dimensions: 9-3/8" x 5-1/2" x 3-3/4"
- 11W LED Lights only
- LED Photo Eye
- When Standard Control Panel is purchased, Masters Decorative Series warranty is 3 years and Standard Control Panel warranty is 1 year.



Upgraded Panels:

- Upgraded Panel dimensions: 16" x 12" x 6"
- 11W or RGBW Lights
- When Upgraded Control Panel is purchased, Masters Decorative Series warranty is 5 years and Upgraded Control Panel warranty is 3 years.

